

## DUPLEX Tx



DUPLEX Tx transmitter modules (along with DUPLEX Rx receivers) constitute the base of a complex system working in the 2,4GHz band, assigned to remote control of models. *These modules may be installed into transmitters which in a convenient way transmit stick and control element positions.* Recently most of available transmitters working with PPM mode are suitable for this purpose.

DUPLEX Tx modules work up data of the transmitter control elements and send them to the corresponding (paired) receiver. Simultaneously they exchange service and telemetric informations with the receiver and take in turn advantage of them for operation optimization.

In order to take full advantage of the DUPLEX system it is advisable to connect the universal terminal JETIBOX to the transmitter module. This way you will be able to adjust easily requested parameters and to display data of transmitter, receiver as well as data of connected telemetric or diagnostic equipment. Another item of the TX-modules is indication of the complete system condition by means of sound signals.

Transmitter modules of the DUPLEX system are offered in form of exchangeable plug-in modules DUPLEX TF, DUPLEX TG as well as modules DUPLEX TU for internal assembly.

Table 1 Basic Data of TX Modules:

Basic data	DUPLEX TU	DUPLEX TF	DUPLEX TG/TGi
Dimensions	55 x 28,8 x 9 mm	59 x 37 x 20 mm	60 x 44 x 21 mm
Weight	15 g	40 g	50 g
Antenna	2 dBi	2 dBi	2 dBi
Acoustic signalling of conditions	•	•	•
Number of input PPM channels	16	16	16
Operation temperature	- 10 to + 85° C	- 10 to + 85° C	- 10 to + 85° C
Supply voltage	3,5 – 16V	3,5 – 16V	3,5 – 16V
Average current	38 mA	38 mA	38 mA
Output power	20 dBm	20 dBm	20 dBm

Table 2 Assignment of Modules and Transmitters

Transmitter / Module	TU	TF	TG	TG internal
<b>Futaba:</b> 7U, 8U, 8J, 9C, 9Z, FN, T10C, 3PK, 3PJ FC-18, FC-28	•	•	–	–
<b>Futaba:</b> FC-16, FC-18 JUNIOR, T6EXHP, 12FG, 12Z, 14MZ, FX-18, FX-14	•	–	–	–
<b>Hitec:</b> Optic 6, Eclipse 7, Prism 7	•	•	–	–
<b>Hitec:</b> Laser 4, Laser 6, Optic 6 sport	•	–	–	–
<b>Graupner/JR:</b> X-347, X-388, X-9303, MX-22, X-3810 ADT, PCM-10S, PCM-10X	•	–	•	–
<b>Graupner/JR:</b> FM-6014, MC-17, MC-18, MC-20, MC-24	•	–	–	•
<b>Graupner:</b> MC-10, MC-12, MC-14, MC-15, MC-16, MC-19, MC-22, MC-16-20, MX-12, MX-16s	•	–	–	–
<b>Multiplex:</b> Serie 7,9,12, Cockpit SX Profi 3000, 4000	•	–	–	–
<b>Other transmitters</b>	•	–	–	–

# DUPLEX Tx



## Installation of DUPLEX TF and DUPLEX TG Modules

DUPLEX TF and TG modules are assigned to transmitters with exchangeable HF plug-in modules. TF modules are compatible to corresponding exchangeable modules of Futaba and Hitec transmitters. TG modules are assigned to Graupner and JR transmitters. Factual assignments see Table 2.

Remove the original HF module of your transmitter and plug-in with the correct orientation of the connector the DUPLEX TF or TG in place of the original module. Screw the Tx-antenna delivered with the Tx module into the module box.

## Installation of the DUPLEX TU Module

Place of destination of the DUPLEX TU transmitter modules are transmitters working in PPM mode, but without having exchangeable HF module.

In this case connection of the module to the transmitter affords certain skill and experience with electronic equipment. The skill necessary depends upon the type of transmitter and upon the manner you intend to connect it up. On PPM transmitters with a „trainer“ connector the transmitter module can be connected to this connector. Other transmitters require removal of the Tx back cover in order to assemble the module DUPLEX TU directly inside the transmitter. For this kind of work we recommend to take advantage of the help of a service station. An acute list of appropriate centers you may find on the home page of [www.jetimodel.com](http://www.jetimodel.com).

### Installation with the Aid of the Trainer Connector

Find the connections of the trainer connector in the instruction manual of your transmitter, connections of several transmitters are shown below. In order to insure correct operation of the DUPLEX TU module you have to interconnect the corresponding pins GND, supply +Ubat and the PPM signal between the transmitter and the IN connector of the module. Mechanically you may fix the module and the connector either to the transmitter case or the transmitter tray.

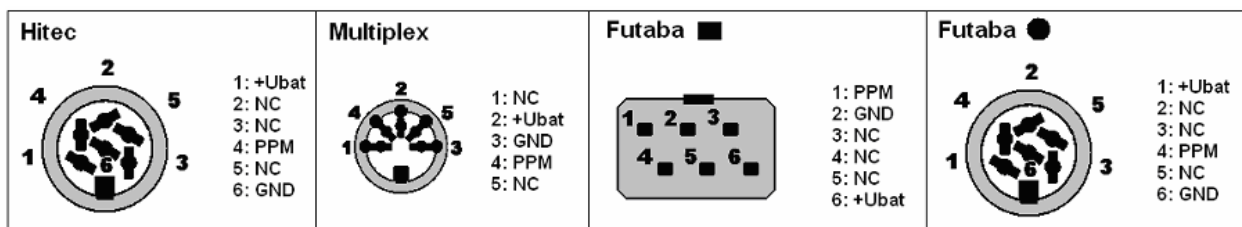

### Internal Installation

Switch off the transmitter and place it on a soft pad in order to prevent mechanical damage. Remove the cover and before proceeding remove batteries. Select an appropriate location in your transmitter for assembly, keeping placement of the antenna connector in mind. Mechanical fixing of the module you may accomplish by means of double sided tape, Velcro fastener or by small screws through holes provided in the module.

For installation of the antenna connector you may usually take advantage of one of the holes provided for additional switches, the hole for the existing antenna 35/40 MHz, or you may drill a 6,5 mm dia. hole at an appropriate location. In any case, the part of the connector protruding through the transmitter wall should be long enough (after screwing the antenna in there must remain at least a small gap between transmitter case and antenna.

The DUPLEX TU module is equipped with two 4-pin connectors marked IN and OUT. The IN connector is specified for the connection of the battery supply and of the PPM signal from the encoder of your transmitter. To the connector OUT you may connect another transmitter module (for instance a

## DUPLEX Tx



redundant module). The supply of this module is provided by the cross connection „FM“ (Fail Safe Module), if the cross connection „FM“ is removed there is no supply at the connector OUT. In a similar manner the supply of the DUPLEX TU can be handled by the cross connection „2,4“ (when the cross connection „2,4“ is removed supply of the DUPLEX TU module is cut).

Examples of accessible installations of well-known transmitters you may find on internet pages of [www.jetimodel.com](http://www.jetimodel.com).

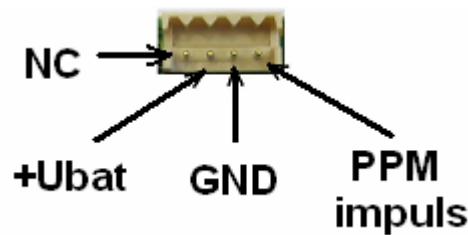
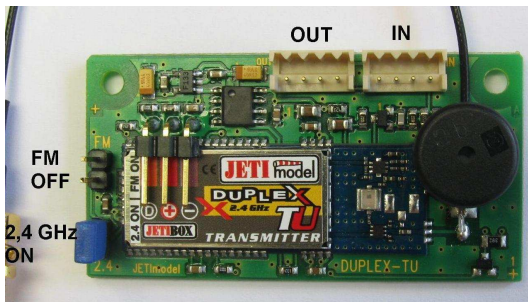

### Putting into operation

#### Pairing with the receiver and performance verification

Any receiver and transmitter module takes advantage of digital transfer for communication purposes, in order to enable direct address communication between the equipment it is necessary to apply the so called pairing between them. The description of a transmitter module is given by its unique address which after pairing to the receiver ensures, that the receiver will accept only data from this definite transmitter. There may be paired as many receivers as you like with the transmitter module, but a receiver can be paired to one transmitter only.

Install the receiver into your model. If the equipment is switched on first time we explicitly recommend to ensure that no detrimental effects on health or property may occur due to unexpected receiver output conditions (for instance badly adjusted mixers, reversed outputs etc.).

Activate receiver pairing by means of the shorting plug (**BIND PLUG**), which is a part of the receiver. **Plug-in the shorting plug into the connector "Ext." and switch on the receiver. Then switch on the transmitter.** If pairing was successful the transmitter will confirm this by a short beep (by a lower and then a higher tone). If no confirmation of a successful pairing occurs, try to repeat the whole procedure or try to verify via the JETIBOX whether the receiver is in „Normal Mode“ (a receiver in „Clone Mode“ is not allowed to transmit and hence cannot confirm pairing). After pairing confirmation remove the BIND PLUG from the receiver connector.

Verify correct reactions of the model to transmitter commands (servo deflections have to follow corresponding stick deflections). If not, check whether servos are plugged into correct positions and the receiver is correctly adjusted (adjustment of mixers etc.). DUPLEX receivers can be reset to original state by the JETIBOX (connected to the receiver) with the help of the menu Autoset-normal.

DUPLEX Tx modules are adapted to cooperate with transmitters working with PPM signals. If the transmitter is switched to PCM mode or the installation has not been performed properly, the transmitter module will emit a repeated alert tone (3x long beep).



## **Range test**

Before initial utilization of the transmitter (or receiver) it is advisable to make a range test and thus verify correct functions of the transmitter and receiver HF circuits. The transmitter can be switched to the test mode by the JETIBOX or by the BIND PLUG.

After connection of the JETIBOX to the transmitter select the item "Range Test" and push the button U (upward arrow). The transmitter will be switched to range test mode and the transmitted power will be decreased to less than 10%. This situation is reported acoustically by interrupted beeps (short and long tone). After pushing the button U again (upward arrow) the transmitter returns to normal state, the output power increases to the normal value and beeping ceases. Test mode activation by means of the BIND PLUG commences analogical to receiver pairing as shown above. However, after the pairing procedure keep the shorting plug plugged in the receiver. As long as the shorting plug remains plugged in, the transmitter will stay in range test mode. In this mode the transmitter behaves in the same way as if range test would have been activated by the JETIBOX. In order to stop this mode remove the shorting plug from the receiver.

Place the model and transmitter at least 80 cm high above ground. A correctly working transmitter and receiver in test mode should have a range of at least 50 m. If not, first of all verify correct antenna installation (transmitter and receiver). If the test still shows no success, do not use the equipment and contact your dealer or a service center.

## **Automatic Test**

The TX module comprises an automatic test system as well. After switching on the receiver and transmitter a quality evaluation of the transmission path including all antennas is being performed. The result is reported 1 second after switching on of the transmitter by an acoustic signal of the TX module. No signal at all after lapse of this period signifies a flawless transmission path. An impaired transmission quality is indicated by one to four tones of the TX module. One single tone can already occur if the model is slightly further away of the transmitter, but the transmission path is OK. If more tones are released check the TX antenna connection as well as positions of the RX antennas and make a range check.

## **Connection of the JETIBOX**

As already mentioned the JETIBOX terminal can be connected to DUPLEX Tx transmitters. With the help of this terminal transmitter data and parameters as well as currently connected equipment (receivers, telemetric sensors etc.) may be displayed and adjusted.

DUPLEX transmitter modules are equipped with a three pin connector (see marking) intended for connection of the JETIBOX. Connection can be easily done by the interconnection cable delivered with the JETIBOX. When connecting pay attention to correct orientation of the connectors. We recommend to connect or disconnect the JETIBOX only, if the transmitter is switched off. When the transmitter has been switched on you will be able to skim through items of the transmitter or other connected equipment with the help of the JETIBOX push buttons.

## **Parameter Adjustment with Help of the JETIBOX**

When connecting the JETIBOX terminal to the transmitter you may select whether you want to display and adjust transmitter parameters (Tx), connected receivers (Rx) or other equipment (Mx) which is able to communicate with the JETIBOX. Communication with Rx and Mx is only possible if the transmitter module and receiver are paired and if there exists a radio link. This situation is shown in the LCD display by a downward showing arrow beside the Mx and Rx text.

After adjustment of the claimed item (Tx/Rx/Mx) push the button D (downward arrow). Afterwards you may skim with help of pushbuttons through the menu of the selected equipment. When working

## DUPLEX Tx



with equipment Rx or Mx you may get back to the transmitter module menu Tx by holding down button U (arrow upward) for a time longer than 2 seconds.

The menu structure of the transmitter module as shown by the JETIBOX see **Diagram**.

### **Summary of Transmitter Items:**

The introductory display shows the transmitter type. By pushing button R (right arrow) the identification numbers of the transmitter module and of the actual paired receiver are displayed.

**Diag** – shows more detailed informations about the transmitter and paired receiver condition.

Identification of the active receiver antenna (**A1/A2**) and of the actual signal intensity rated from 0 to 9 (best).

On the right side according to condition the following indicators may be shown:

**R** - Range Test mode (range test)

**P** - after switching on the transmitter has not yet been paired (did for the moment not find a paired receiver)

**S** - there are no receiver data available (bad signal)

**T** - low voltage of the transmitter battery

**B** - low voltage of the receiver battery

**I** - there are no PPM pulses from the transmitter accessible (installation error, PCM mode etc.)

Most of the conditions shown are accompanied by acoustic signals.

By pushing button U (upward arrow) range test mode may be activated.

**ImpDiag** – shows the actual number of transmitter PPM channels (**K2** till **K16**, depends on transmitter type)

**Volt MIN/ACT/MAX** - minimum, actual and maximum value of transmitter module supply voltage. Reset („zeroing“) of the min. and max. values is always executed when the transmitter is switched on and after location of the paired receiver. Alternatively the displayed values may be reset by simultaneously pushing buttons L and R (left and right arrow).

**Rx Signal Level** – shows the actual signal intensities of individual RX antennas. The intensity is shown in steps from 0 till 9 and the highest rating of 9 indicates the best reception of a particular antenna. A dash (-) indicates that the TX module is not receiving any informations about the reception quality of the particular antenna. Either the receiver is not connected or backward transmission from the receiver to the transmitter is at the range limit.

**Volt ACT/ALARM** – shows the actual value of transmitter module supply voltage and the adjusted limit for an alert signal "T" (see menu Diag). By buttons L and R (JETIBOX buttons -left or right) the alert start limit may be adjusted.

**Mx Tone 1** – enables adjustment of warning tone frequency (Hz), which reveals alert conditions of the connected equipment Mx (usually a telemetric sensor). A value of 0 indicates that the warning tone is switched off.

**Mx Tone 2** - enables adjustment of information tone frequency (Hz), which informs about the alert condition of the connected equipment Mx. This tone has Morse alphabet character and follows immediately after the warning tone. A value of 0 indicates that the information tone is switched off.



## Acoustical Condition Signalling

All types of transmitter modules are equipped with an acoustic output which is utilized for signalling of different transmitter, receiver or attached telemetric sensor conditions. The following conditions are reported by acoustic signals:

- I ( \_ \_ \_ ) 3x long low tone  
PPM pulses of the transmitter are not accessible (installation error, PCM mode etc.)
- P ( . - ) short low tone and consecutive high tone -  
a paired receiver has been found
- B ( - ) long high beep  
low receiver battery supply voltage
- T ( \* ) short high beep  
low transmitter battery supply voltage
- S ( \* \* ) 2x short high beep  
there are no receiver data available (bad signal)
- R ( . . . - ) alternating short and long tones  
Range Test mode (range test)
  
- M alert indication from attached telemetric sensor  
first beep (revelation tone) corresponding to adjusted value Mx Tone 1  
consecutively a Morse alphabet beep (information tone due to adjustment Mx Tone 2)  
Alert indication by Morse alphabet signal, character of signal is given by the type and adjustment of attached equipment (receiver, telemetric sensor etc.).

For Tx modules we grant a warranty of 24 months from the day of purchase under the assumption that they have been operated in conformity with these instructions at recommended voltages and that they were not damaged mechanically. Warranty and post warranty service is provided by the manufacturer.

We wish you successful flying with the products of : JETI model s.r.o. Pribor, [www.jetimodel.com](http://www.jetimodel.com)

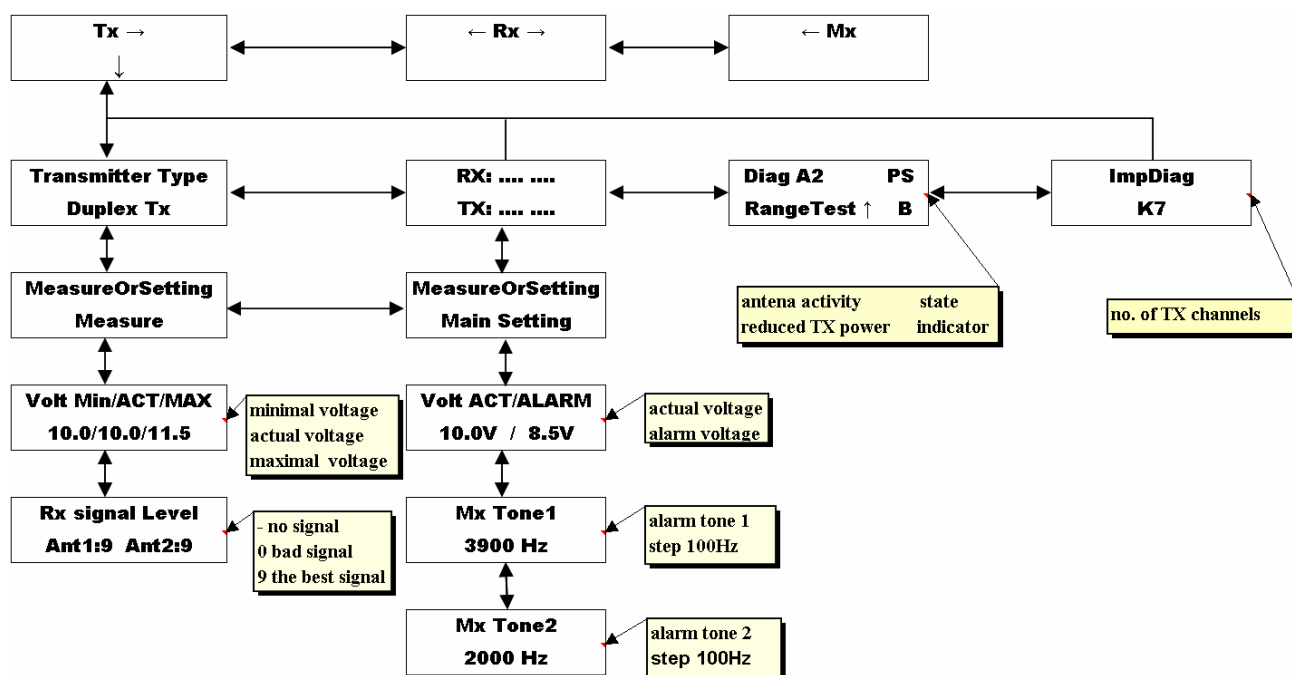

**DUPLEX Tx**

